

Heiko Körte
Director Sales & Marketing

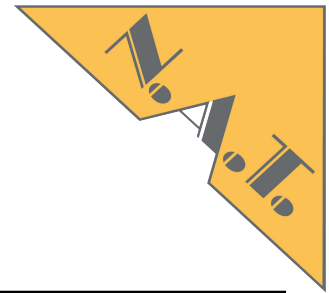

Session #1

μ TCA™ in practise:

Applications and Fat Pipes – future of fat pipes ?

μ TCA Day, November 3rd, 2009

NH Hotel München Dornach

Motivation



μ TCA™ in practise: Apps & Fat Pipes
future of fat pipes ?

- “Fat Pipes”
 - What is a “fat pipe” ?
 - Which “fat pipes” are defined ?
 - What “fat pipe” to use for my application ?
- Combining “fat pipes”
 - Are there any standard definitions ?
 - What is the impact on my system architecture ?
- Solutions available in the future

Agenda



μ TCA™ in practise: Apps & Fat Pipes
future of fat pipes ?

- “Fat Pipes”
 - What is a “fat pipe” ?
 - Which “fat pipes” are defined ?
 - What “fat pipe” to use for my application ?
- Combining “fat pipes”
 - Are there any standard definitions ?
 - What is the impact on my system architecture ?
- Solutions available in the future

Agenda



μ TCA™ in practise: Apps & Fat Pipes
future of fat pipes ?

- "Fat Pipes"
 - What is a "fat pipe" ?
 - Which "fat pipes" are defined ?
 - What "fat pipe" to use for my application ?
- Combining "fat pipes"
 - Are there any standard definitions ?
 - What is the impact on my system architecture ?
- Solutions available in the future

What is a "Fat Pipe"?

Location in a μ TCA System



μ TCA™ in practise: Apps & Fat Pipes
future of fat pipes ?

- Components of a μ TCA shelf

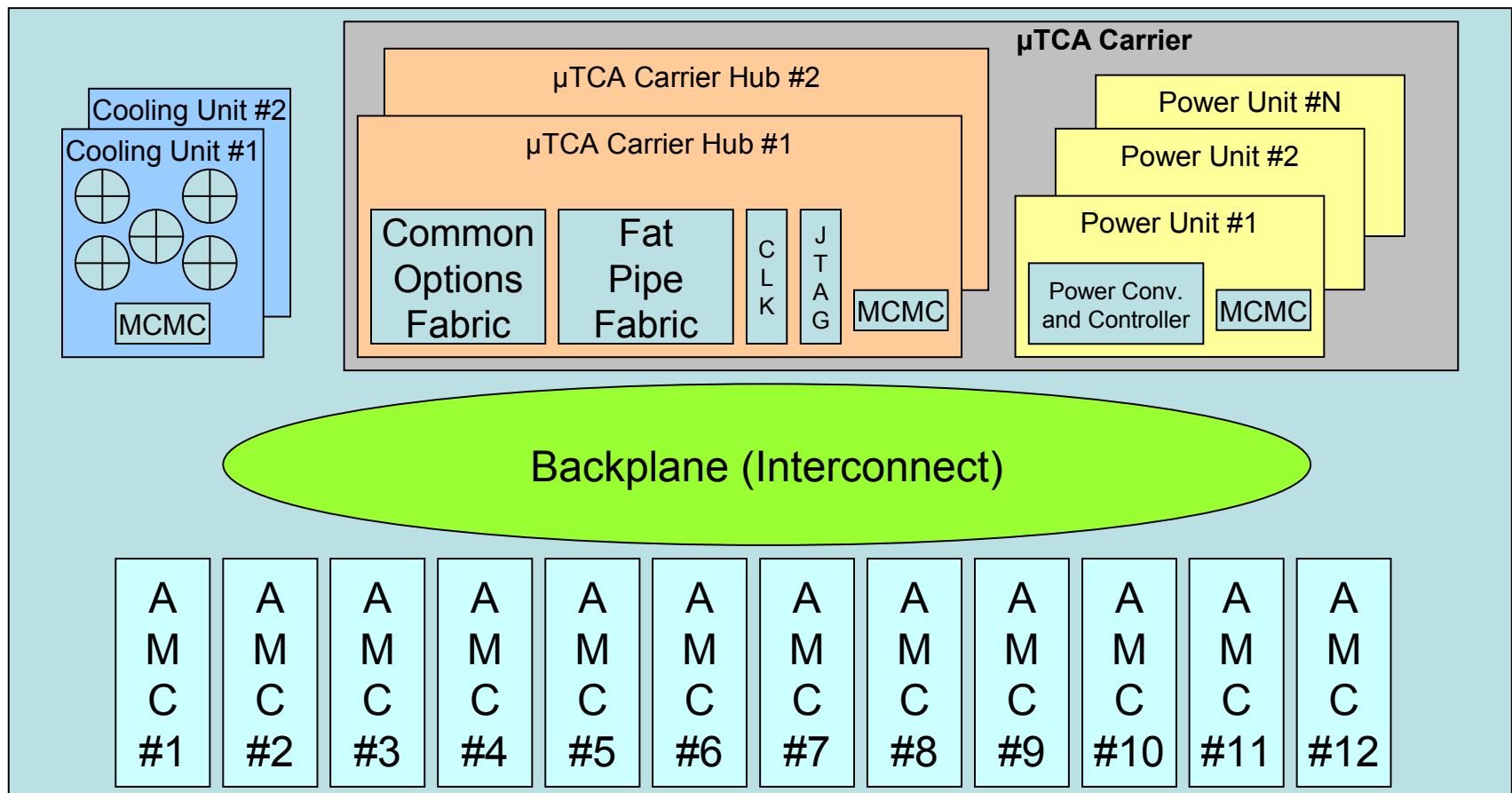



What is a "Fat Pipe"?

Serial Data Transmission

- Bits are transmitted one after the other over single data line
- Every data byte (8bit) is transformed to 10bit symbol that contains enough transitions

→ 8B/10B Coding

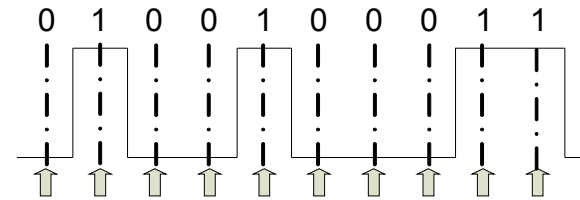

- Clock is recovered from serial stream
- Bidirectional transmission via dedicated Tx and Rx lines
 - One Tx/Rx pair is called "**Lane**"

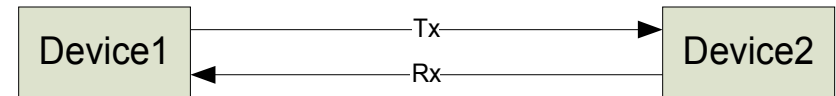

- Multiple Devices interconnect realized with **Switches**

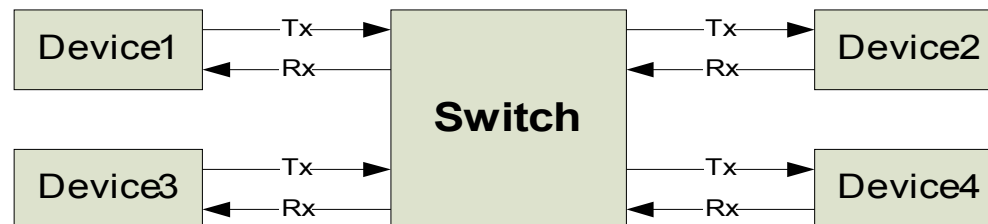

What is a "Fat Pipe"?

Serial Data Transmission



μTCA™ in practise: Apps & Fat Pipes
future of fat pipes ?



- Very high frequencies: > 1Ghz
 - No per-cycle-relation to other signal needed
 - point-to-point connections only
- Differential Signaling
 - Better immunity to disturbances and interferences
- Bandwidth is determined/limited by:
 - Maximum frequency depends on chip technology and interconnect quality
 - Example: Harting MCH/AMC plugs and backplane connectors are specified with 6,125GHz
 - Multiple Lanes are used in parallel to increase bandwidth

- The whole signal path is important!

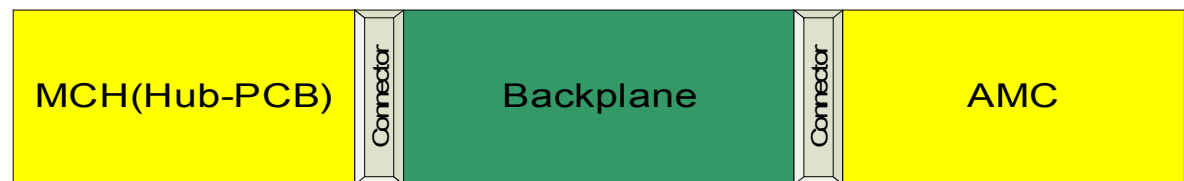

slide 7

Agenda



μ TCA™ in practise: Apps & Fat Pipes
future of fat pipes ?

- “Fat Pipes”
 - What is a “fat pipe” ?
 - Which “fat pipes” are defined ?
 - What “fat pipe” to use for my application ?
- Combining “fat pipes”
 - Are there any standard definitions ?
 - What is the impact on my system architecture ?
- Solutions available in the future

Definition of "Fat Pipes"

Overview



μ TCA™ in practise: Apps & Fat Pipes
future of fat pipes ?

- Defined in PICMG AMC.x series (the "Fabrics"):
 - AMC.0 – Base Specification
 - AMC.1 – PCI Express (PCIe)
 - AMC.2 – Ethernet (1GbE and 10GbE/XAUI)
 - AMC.3 – Storage (SAS/SATA)
 - AMC.4 – Serial Rapid I/O (SRIO)

Definition of "Fat Pipes"

PCIe – Programmer's Darling



μTCA™ in practise: Apps & Fat Pipes
future of fat pipes ?



- 2,5Gbit/s raw bit frequency
 - After 8B/10B decoding 2Gbit/s transmission speed
 - Results in ~250MByte/s effective data rate per lane
 - Within μTCA: up to 4 lanes in parallel → ~1GByte/s
- Centralized architecture
 - Host required (upstream port)
 - Difficult to set up redundant systems (non-transparent upstream port)
- Software compatible to PCI
 - Comfortable for Programmer: Simple memory mapped accesses
- (Hardware-) Integrated:
 - Protocol Error Detection, Correction and Reporting
 - Flow Control and Quality-of-Service (Prioritization)



Definition of "Fat Pipes"

1GbE – the well-known Ethernet



μTCA™ in practise: Apps & Fat Pipes
future of fat pipes ?

- One lane with 1.25Gbit/s → 1Gbit/s after 8b/10b decoding per direction
- Decentralized communication model
 - easy to build up redundant systems
 - each device has unique MAC-address
- Suited for data exchange beyond the system barriers
 - no Data reorganization needed for direct connect to LANs
 - example: standard PC can be integrated in μTCA setup
- Data integrity is ensured by higher layer protocols
=> high amount of computing resources required

Definition of "Fat Pipes"

10GbE – Ethernet with turbo



μTCA™ in practise: Apps & Fat Pipes
future of fat pipes ?

- 4 lanes at 3.125Gbit/s per lane per direction
 - resulting in 2.5Gbit/s per lane per direction after 8b/10b decoding => 10Gbit/s per direction in total
- 20 port XAUI switch from Fulcrum Microsystems (FM2220) on XAUI hub mezzanine
- Basic Features:
 - port speed selectable per port:
 - XAUI (10GbE) or
 - 2.5GbE or
 - 1GbE
 - 2 uplink ports on faceplate
 - 10GBase-CX4

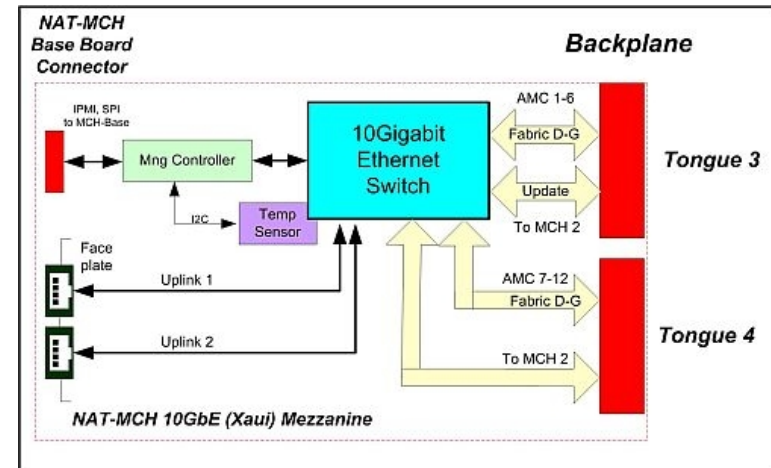

Definition of "Fat Pipes"

10GbE – Ethernet with turbo



μTCA™ in practise: Apps & Fat Pipes
future of fat pipes ?

- Security Features:
 - MAC address security
 - port access control
- Layer2 Bridging Features:
 - spanning tree
 - VPN priority
 - link aggregation
 - duplex flow control
 - traffic shaping

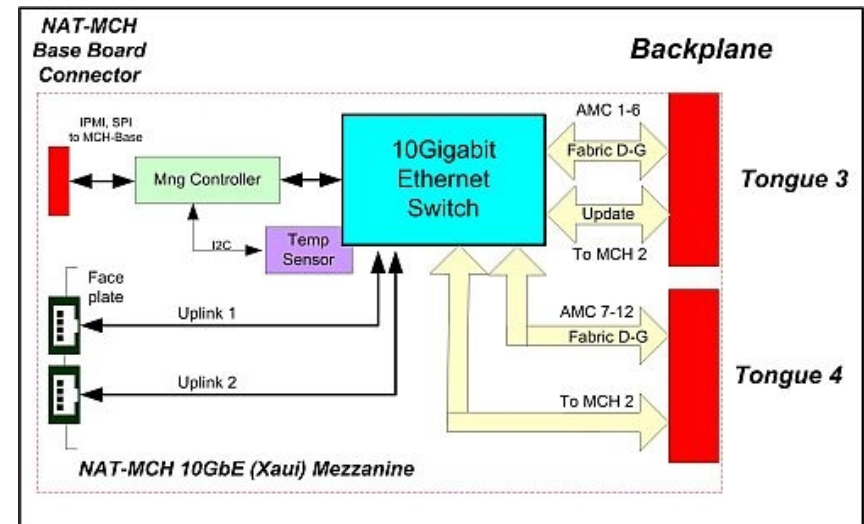

Definition of "Fat Pipes"

SRIO – combining advantages



μTCA™ in practise: Apps & Fat Pipes
future of fat pipes ?



- x1 or x4 SRIO with configurable speed per port:
 - 1.25Gbps per direction
 - 2.5Gbps per direction
 - 3.125Gbps per direction
- 👉 Link partners must be set to same speed!
 - > max. 10Gbps per direction after 8b/10b decoding
- Decentralized communication model
 - > No host required
 - Peer-to-Peer communication
 - Easy to build up redundant systems
- Memory mapped access possible
- Hardware data integrity

Definition of "Fat Pipes"

SRIO – combining advantages



μTCA™ in practise: Apps & Fat Pipes
future of fat pipes ?

- still not well recognized ("Is this new ?")
- growing silicon ecosystem (CPUs, DSPs, FPGAs)
- high-speed chip-to-chip and/or board-to-board connection
 - no protocol conversion needed
- Features of Tundra TSI578:
 - very low port-to-port latency (min. 112ns)
 - hardware multicast
 - packet prioritization

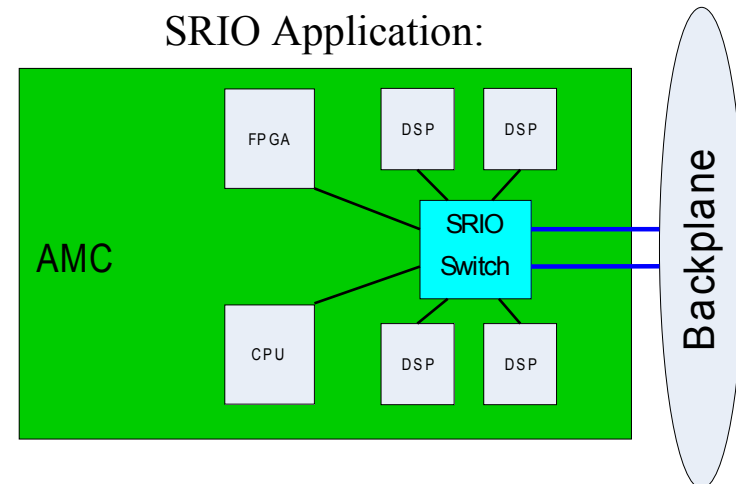

Agenda



μ TCA™ in practise: Apps & Fat Pipes
future of fat pipes ?

- “Fat Pipes”
 - What is a “fat pipe” ?
 - Which “fat pipes” are defined ?
 - What “fat pipe” to use for my application ?
- Combining “fat pipes”
 - Are there any standard definitions ?
 - What is the impact on my system architecture ?
- Solutions available in the future

Which "Fat Pipes" ?

fabric comparison and applications



μTCA™ in practise: Apps & Fat Pipes
future of fat pipes ?

Protocol	PCIe	10 GbE	SRIO
Advantage	<ul style="list-style-type: none"> Memory mapped access Software compatible to PCI 	<ul style="list-style-type: none"> Not only for system internal connectivity Data is ready for connect direct to LAN 	<ul style="list-style-type: none"> Hardware data integrity Memory mapped access
Disadvantage	<ul style="list-style-type: none"> Host needed 	<ul style="list-style-type: none"> High Software Overhead 	<ul style="list-style-type: none"> ???
Typical Application	<ul style="list-style-type: none"> Processing Blade Next generation Industrial PC 	<ul style="list-style-type: none"> Media Gateway Network Convergence 	<ul style="list-style-type: none"> Distributed Data processing or Data Acquisition

Which "Fat Pipes" ?

fabric comparison and applications

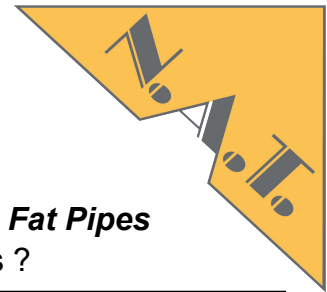

μTCA™ in practise: Apps & Fat Pipes
future of fat pipes ?

Protocol	PCIe	10 GbE	SRIO
Used in	<ul style="list-style-type: none"> Automation Medical Defense (Tele-)coms 	<ul style="list-style-type: none"> Defense Telecom 	<ul style="list-style-type: none"> Automation Medical Defense Telecoms
Formfactors	<ul style="list-style-type: none"> 19" 1-5U Table Top 	<ul style="list-style-type: none"> 19" 1-5U 	<ul style="list-style-type: none"> 19" 1-5U Table Top
Specialities	<ul style="list-style-type: none"> Redundancy Clustering 	<ul style="list-style-type: none"> Redundancy Trunking 	<ul style="list-style-type: none"> Redundancy Inter-system links



Motivation

- “Fat Pipes”
 - What is a “fat pipe” ?
 - Which “fat pipes” are defined ?
 - What “fat pipe” to use for my application ?
- Combining “fat pipes”
 - Are there any standard definitions ?
 - What is the impact on my system architecture ?
- Solutions available in the future

Combining "Fat Pipes"

Are there any standards ?



μTCA™ in practise: Apps & Fat Pipes
future of fat pipes ?



- There definitely are standards:

-> defined by PICMG:

- AMC.0: AMC base specification
- AMC.1: PCIe
- AMC.2: Ethernet (1GbE and 10GbE)
- AMC.3: Storage (SAS/SATA)
- AMC.4: SRIO
- MTCA.0: uTCA base specification



- PICMG: PCI Industrial Manufacturers Group

"PICMG is a consortium of companies who collaboratively develop open specifications for high performance telecommunications and industrial computing applications."

-> www.picmg.org

Combining "Fat Pipes"

PICMG AMC-to-MCH port mapping

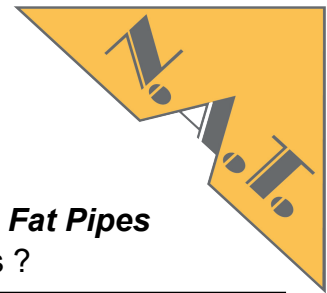

μTCA™ in practise: Apps & Fat Pipes
future of fat pipes ?

Con.	Region	Port	Function	1x MCH	2x MCH
Basic Side	Clock	TCKLA	Telecom Clock A	CLK1	1-CLK1
		TCLKB	Telecom Clock B	CLK2	1+2-CLK2
		FCLK	Fabric Clock or redundant TCLKA	CLK3	2-CLK1
	Common Options	0	1GbE	1-A	1-A
		1	redundant 1GbE		2-A
		2	SAS/SATA	1-B	1-B
		3	redundant SAS/SATA		2-B
	Fat Pipe	4	PCIe or 10GbE or SRIO	1-D	1-D
		5	PCIe or 10GbE or SRIO	1-E	1-E
		6	PCIe or 10GbE or SRIO	1-F	1-F
		7	PCIe or 10GbE or SRIO	1-G	1-G
Extended Side	Extended Fat Pipe	8	1GbE or 10GbE or SRIO		2-D
		9	1GbE or 10GbE or SRIO		2-E
		10	1GbE or 10GbE or SRIO		2-F
		11	1GbE or 10GbE or SRIO		2-G
	Extended Options	12			
		13			
		14			
		15			
		TCLKC+D	Telecom Clocks C+D		
		17			
18					
19					
20					

AMC to MCH port mapping according to PICMG



Combining "Fat Pipes"

Are there any other standards ?



μTCA™ in practise: Apps & Fat Pipes
future of fat pipes ?



- based on the PICMG definitions there are other requests from industrial users
- SCOPE Alliance:
"SCOPE is an association of Network Equipment Providers aimed at accelerating the deployment of Carrier Grade Base Platforms for service provider applications."
„SCOPE's mission is to enable and promote the availability of open carrier grade base platforms based on Commercial Off The Shelf (COTS) hardware / software and free open source software building blocks, and to promote interoperability to better serve Service Providers and consumers."

-> www.scope-alliance.org



Combining "Fat Pipes"

SCOPE AMC-to-MCH port mapping



μTCA™ in practise: Apps & Fat Pipes
future of fat pipes ?

Con.	Region	Port	Function	1x MCH	2x MCH
Basic Side	Clock	TCKLA	Telecom Clock A	CLK1	1-CLK1
		TCLKB	Telecom Clock B	CLK2	1-CLK2
		FCLK	Fabric Clock or redundant TCLKA	CLK3	1-CLK3
	Common Options	0	1GbE	1-A	1-A
		1	redundant 1GbE		2-A
		2	SAS/SATA		
		3	redundant SAS/SATA		
	Fat Pipe	4	Point-2-Point, e.g. PCIe		
		5	Point-2-Point, e.g. PCIe		
		6	Point-2-Point, e.g. PCIe		
		7	Point-2-Point, e.g. PCIe		
Extended Side	Extended Fat Pipe	8	1GbE or 10GbE or SRIO	1-D	1-D
		9	1GbE or 10GbE or SRIO	1-E	1-E
		10	1GbE or 10GbE or SRIO	1-F	1-F
		11	1GbE or 10GbE or SRIO	1-G	1-G
	Extended Options	12	APS or Point-2-Point or rearIO		
		13	Point-2-Point or rearIO		
		14	Point-2-Point or rearIO		
		15	Point-2-Point or rearIO		
		TCLKC+D	Telecom Clocks C+D		2-CLK1+2
		17	1GbE or 10GbE or SRIO		2-G
		18	1GbE or 10GbE or SRIO		2-F
		19	1GbE or 10GbE or SRIO		2-E
		20	1GbE or 10GbE or SRIO		2-D

AMC to MCH port mapping according to SCOPE





Motivation

- “Fat Pipes”
 - What is a “fat pipe” ?
 - Which “fat pipes” are defined ?
 - What “fat pipe” to use for my application ?
- Combining “fat pipes”
 - Are there any standard definitions ?
 - What is the impact on my system architecture ?
- Solutions available in the future

Combining "Fat Pipes"

PICMG vs. SCOPE

impact on system architecture



μTCA™ in practise: Apps & Fat Pipes
future of fat pipes ?



- Problem:

SCOPE has a different port mapping than
PICMG

- Question: does the SCOPE approach specially
designed components?

Potentially affected components:

- MCH
- AMCs
- backplane

Combining "Fat Pipes"

PICMG vs. SCOPE

impact on MCH



μTCA™ in practise: Apps & Fat Pipes
future of fat pipes ?

Con.	Region	Port	Function	1x MCH	2x MCH	1x MCH	2x MCH
Basic Side	Clock	TCKLA	Telecom Clock A	CLK1	1-CLK1	CLK1	1-CLK1
		TCLKB	Telecom Clock B	CLK2	1+2-CLK2	CLK2	1-CLK2
		FCLK	Fabric Clock or redundant TCLKA	CLK3	2-CLK1	CLK3	1-CLK3
	Common Options	0	1GbE	1-A	1-A	1-A	1-A
		1	redundant 1GbE		2-A		2-A
		2	SAS/SATA	1-B	1-B		
		3	redundant SAS/SATA		2-B		
	Fat Pipe	4	PCIe or 10GbE or SRIO	1-D	1-D		
		5	PCIe or 10GbE or SRIO	1-E	1-E		
		6	PCIe or 10GbE or SRIO	1-F	1-F		
7		PCIe or 10GbE or SRIO	1-G	1-G			
Extended Side	Extended Fat Pipe	8	1GbE or 10GbE or SRIO		2-D	1-D	1-D
		9	1GbE or 10GbE or SRIO		2-E	1-E	1-E
		10	1GbE or 10GbE or SRIO		2-F	1-F	1-F
		11	1GbE or 10GbE or SRIO		2-G	1-G	1-G
	Extended Options	12	APS or Point-2-Point or rearIO				
		13	Point-2-Point or rearIO				
		14	Point-2-Point or rearIO				
		15	Point-2-Point or rearIO				
		TCLKC+D	Telecom Clocks C+D				
		17	1GbE or 10GbE or SRIO				2-CLK1+2
		18	1GbE or 10GbE or SRIO				2-G
		19	1GbE or 10GbE or SRIO				2-F
		20	1GbE or 10GbE or SRIO				2-E
						2-D	

PICMG

SCOPE

Combining "Fat Pipes"

PICMG vs. SCOPE

impact on system architecture



μTCA™ in practise: Apps & Fat Pipes
future of fat pipes ?



- Problem:

SCOPE has a different port mapping than
PICMG

- Question: does the SCOPE approach specially
designed components?

Potentially affected components:

- ✓ **MCH**
 - AMCs
 - backplane

Combining "Fat Pipes"

PICMG vs. SCOPE

impact on AMCs

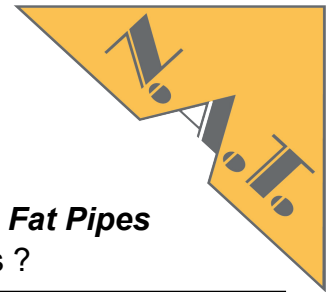

μTCA™ in practise: Apps & Fat Pipes
future of fat pipes ?

Con.	Region	Port
Basic Side	Clock	TCKLA
		TCLKB
		FCLK
	Common Options	0
		1
		2
		3
	Fat Pipe	4
		5
		6
7		
Extended Side	Extended Fat Pipe	8
		9
		10
		11
		11
	Extended Options	12
		13
		14
		15
		TCLKC+D
17		
18		
19		
20		

Function
Telecom Clock A
Telecom Clock B
Fabric Clock or redundant TCLKA
1GbE
redundant 1GbE
SAS/SATA
redundant SAS/SATA
PCIe or 10GbE or SRIO
PCIe or 10GbE or SRIO
PCIe or 10GbE or SRIO
PCIe or 10GbE or SRIO
1GbE or 10GbE or SRIO
1GbE or 10GbE or SRIO
1GbE or 10GbE or SRIO
1GbE or 10GbE or SRIO
Telecom Clocks C+D

PICMG

Function
Telecom Clock A
Telecom Clock B
Fabric Clock or redundant TCLKA
1GbE
redundant 1GbE
SAS/SATA
redundant SAS/SATA
Point-2-Point, e.g. PCIe
Point-2-Point, e.g. PCIe
Point-2-Point, e.g. PCIe
Point-2-Point, e.g. PCIe
1GbE or 10GbE or SRIO
1GbE or 10GbE or SRIO
1GbE or 10GbE or SRIO
1GbE or 10GbE or SRIO
1GbE or 10GbE or SRIO
APS or Point-2-Point or rearIO
Point-2-Point or rearIO
Point-2-Point or rearIO
Point-2-Point or rearIO
Telecom Clocks C+D
1GbE or 10GbE or SRIO
1GbE or 10GbE or SRIO
1GbE or 10GbE or SRIO
1GbE or 10GbE or SRIO

OK

Combining "Fat Pipes"

PICMG vs. SCOPE

impact on system architecture



μTCA™ in practise: Apps & Fat Pipes
future of fat pipes ?

- Problem:

SCOPE has a different port mapping than
PICMG

- Question: does the SCOPE approach specially
designed components?

Potentially affected components:

- ✓ **MCH**
- ✓ **AMCs**
- backplane

Combining "Fat Pipes"

PICMG vs. SCOPE

impact on system architecture



μTCA™ in practise: Apps & Fat Pipes
future of fat pipes ?



- Problem:

SCOPE has a different port mapping than
PICMG

- Question: does the SCOPE approach specially
designed components?

Potentially affected components:

- ✓ **MCH**
- ✓ **AMCs**
- ✓ **Backplane**

- Answer: yes, it does !

Agenda



μ TCA™ in practise: Apps & Fat Pipes
future of fat pipes ?

- “Fat Pipes”
 - What is a “fat pipe” ?
 - Which “fat pipes” are defined ?
 - What “fat pipe” to use for my application ?
- Combining “fat pipes”
 - Are there any standard definitions ?
 - What is the impact on my system architecture ?
- Solutions available in the future



Solutions in the future

μTCA™ in practise: Apps & Fat Pipes
future of fat pipes ?

- SCOPE is representing an important momentum in the market:
 - New standards in communication systems:
 - driven by big **tele**communication **co**mpanies (**TelCo**) and IC Manufactures
 - reflect the structure/challenges of next generation networks:

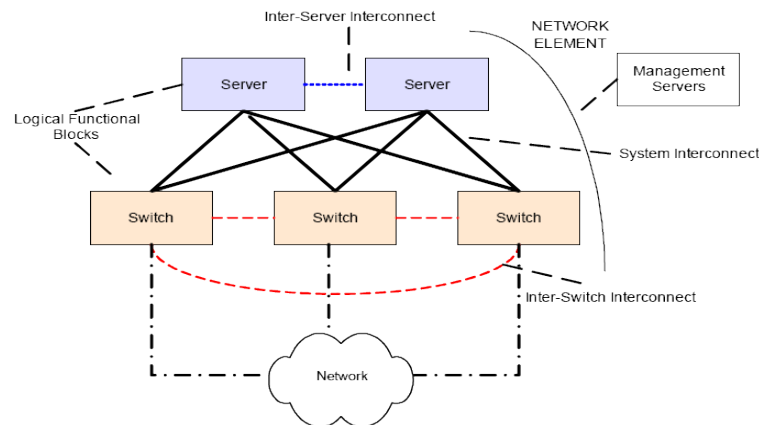

- However: SCOPE users are not the only ones !

Solutions in the future



μTCA™ in practise: Apps & Fat Pipes
future of fat pipes ?



- Consequences:

- AMCs:

- vendors with SCOPE customers will support both
- vendors with mainly non-SCOPE customers will support PICMG only

- backplanes:

- vendors will have two product lines

- MCH:

- a PICMG standard compliant MCH will support both
- MCH will provide switches with „inter-fabric“ routing:
 - PCIe – SRIO
 - XAUI - SRIO

Summary



μ TCA™ in practise: Apps & Fat Pipes
future of fat pipes ?

- “Fat Pipes”
 - What is a “fat pipe” ?
 - Which “fat pipes” are defined ?
 - What “fat pipe” to use for my application ?
- Combining “fat pipes”
 - Are there any standard definitions ?
 - What is the impact on my system architecture ?
- Solutions available in the future

Round Up

The last slide ...



μTCA™ in practise: Apps & Fat Pipes
future of fat pipes ?

This was it ...

I know, you have heard what I said ...

... but ...



... I am not sure if this was what I meant ...